



User Manual

GeoMax Zone40 T

English

Version 1.0

Introduction

Purchase

Congratulations on the purchase of a GeoMax Rotating Laser product.



This manual contains important safety directions as well as instructions for setting up the product and operating it. Refer to [1 Safety Directions](#) for further information.

Read carefully through the User Manual before you switch on the product.



The content of this document is subject to change without prior notice. Ensure that the product is used in accordance with the latest version of this document.

Updated versions are available for download at the following Internet address:

<https://geomax-positioning.com/partner-area>

Product identification



The model and serial number of your product are indicated on the type label.

Always refer to this information when contacting your agency or GeoMax authorised service centre.

Validity of this manual

This manual applies to the Zone40 T lasers.

Available documentation

Name	Description/Format		
Zone40 T Quick Guide	Provides an overview of the product. Intended as a quick reference guide.	✓	✓
Zone40 T User Manual	All instructions required in order to operate the product to a basic level are contained in the User Manual. Provides an overview of the product together with technical data and safety directions.	-	✓

Refer to the following resources for all Zone40 T documentation/software:

- the GeoMax Zone40 T CD
- the GeoMax website: geomax-positioning.com



Table of Contents

1	Safety Directions	4
1.1	General	4
1.2	Definition of Use	5
1.3	Limits of Use	5
1.4	Responsibilities	5
1.5	Hazards of Use	5
1.6	Laser Classification	9
	1.6.1 General	9
	1.6.2 Zone40 T	9
1.7	Electromagnetic Compatibility (EMC)	10
2	Description of the System	12
2.1	System Components	12
2.2	Zone40 T Laser Components	13
2.3	Case Components	13
2.4	Setup	13
3	Operation	15
3.1	Control Panel	15
3.2	Turning the Zone40 T On and Off	15
3.3	LED Indicators	15
3.4	Automatic Mode	16
3.5	Manual Mode	16
3.6	Height of Instrument Alert (H.I.Alert) function	17
4	Receiver	18
4.1	ZRB90, Basic Receiver	18
4.2	ZRP105, Pro Receiver	19
4.3	ZRD105, Digital Receiver	21
5	Applications	22
5.1	Setting Forms	22
6	Batteries	23
6.1	Operating Principles	23
6.2	Battery for Zone40 T	23
7	Accuracy Adjustment	26
7.1	Checking the Level Accuracy	26
7.2	Adjusting the Self-Levelling Accuracy	26
8	Troubleshooting	28
8.1	Zone40 T	28
9	Care and Transport	30
9.1	Transport	30
9.2	Storage	30
9.3	Cleaning and Drying	30
10	Technical Data	32
10.1	Conformity to National Regulations	32
10.2	Dangerous Goods Regulations	33
10.3	General Technical Data of the Product	34
	10.3.1 Charger and Batteries	35

1 Safety Directions

1.1 General

Description

The following directions enable the person responsible for the product, and the person who actually uses the equipment, to anticipate and avoid operational hazards.

The person responsible for the product must ensure that all users understand these directions and adhere to them.

About warning messages





Warning messages are an essential part of the safety concept of the instrument. They appear wherever hazards or hazardous situations can occur.

Warning messages...



- make the user alert about direct and indirect hazards concerning the use of the product.
- contain general rules of behaviour.

For the users' safety, all safety instructions and safety messages shall be strictly observed and followed! Therefore, the manual must always be available to all persons performing any tasks described here.

DANGER, WARNING, CAUTION and **NOTICE** are standardised signal words for identifying levels of hazards and risks related to personal injury and property damage. For your safety, it is important to read and fully understand the following table with the different signal words and their definitions! Supplementary safety information symbols may be placed within a warning message as well as supplementary text.

Type	Description
 DANGER	Indicates an imminently hazardous situation which, if not avoided, will result in death or serious injury.
 WARNING	Indicates a potentially hazardous situation or an unintended use which, if not avoided, could result in death or serious injury.
 CAUTION	Indicates a potentially hazardous situation or an unintended use which, if not avoided, may result in minor or moderate injury.
 NOTICE	Indicates a potentially hazardous situation or an unintended use which, if not avoided, may result in appreciable material, financial and environmental damage.
	Important paragraphs which must be adhered to in practice as they enable the product to be used in a technically correct and efficient manner.

Additional symbols

	Warning against explosive material.
	Warning against flammable substances.
	Product must not be opened or modified or tampered with.



Indicates the temperature limits at which the product may be stored, transported or used.

1.2

Definition of Use

Intended use

- The product casts a horizontal laser plane or a laser beam for the purpose of alignment
- The laser beam can be detected by means of a laser detector

Reasonably foreseeable misuse

- Use of the product without instructions
- Use outside of the intended use and limits
- Disabling of safety systems
- Removal of hazard notices
- Opening the product using tools, for example a screwdriver, unless this is permitted for certain functions
- Modification or conversion of the product
- Use after misappropriation
- Use of products with recognisable damage or defects
- Use with accessories from other manufacturers without the prior explicit approval of GeoMax
- Inadequate safeguards at the working site

1.3

Limits of Use

Environment

Suitable for use in an atmosphere appropriate for permanent human habitation. Not suitable for use in aggressive or explosive environments.

WARNING

Working in hazardous areas or close to electrical installations or similar situations

Life Risk.

Precautions:

- ▶ Local safety authorities and safety experts must be contacted by the person responsible for the product before working in such conditions.

1.4

Responsibilities

Manufacturer of the product

GeoMax AG, CH-9443 Widnau, hereinafter referred to as GeoMax, is responsible for supplying the product, including the user manual and original accessories, in a safe condition.

Person responsible for the product

The person responsible for the product has the following duties:

- To understand the safety instructions on the product and the instructions in the User Manual
- To ensure that the product is used in accordance with the instructions
- To be familiar with local regulations relating to safety and accident prevention
- To stop operating the system and inform GeoMax immediately if the product and the application become unsafe
- To ensure that the national laws, regulations and conditions for the operation of the products are respected

1.5

Hazards of Use

NOTICE

Dropping, misusing, modifying, storing the product for long periods or transporting the product

Watch out for erroneous measurement results.

Precautions:

- ▶ Periodically carry out test measurements and perform the field adjustments indicated in the User Manual, particularly after the product has been subjected to abnormal use as well as before and after important measurements.

⚠ WARNING

Inadequate securing of the working site

This can lead to dangerous situations, for example in traffic, on building sites and at industrial installations.

Precautions:

- ▶ Always ensure that the working site is adequately secured.
- ▶ Adhere to the regulations governing safety, accident prevention and road traffic.

⚠ CAUTION

Not properly secured accessories

If the accessories used with the product are not properly secured and the product is subjected to mechanical shock, for example blows or falling, the product may be damaged or people can sustain injury.

Precautions:

- ▶ When setting up the product, make sure that the accessories are correctly adapted, fitted, secured, and locked in position.
- ▶ Avoid subjecting the product to mechanical stress.

⚠ WARNING

Distraction/loss of attention

During dynamic applications, for example stakeout procedures, there is a danger of accidents occurring if the user does not pay attention to the environmental conditions around, for example obstacles, excavations or traffic.

Precautions:

- ▶ The person responsible for the product must make all users fully aware of the existing dangers.

⚠ WARNING

Improper disposal

If the product is improperly disposed of, the following can happen:

- If polymer parts are burnt, poisonous gases are produced which may impair health.
- If batteries are damaged or are heated strongly, they can explode and cause poisoning, burning, corrosion or environmental contamination.
- By disposing of the product irresponsibly you may enable unauthorised persons to use it in contravention of the regulations, exposing themselves and third parties to the risk of severe injury and rendering the environment liable to contamination.

Precautions:

▶



The product must not be disposed with household waste. Dispose of the product appropriately in accordance with the national regulations in force in your country. Always prevent access to the product by unauthorised personnel.

Product-specific treatment and waste management information can be downloaded from the GeoMax website at <http://www.geomax-positioning.com/treatment> or received from your GeoMax distributor.

⚠ WARNING

Improperly repaired equipment

Risk of injuries to users and equipment destruction due to lack of repair knowledge.

Precautions:

- ▶ Only authorised GeoMax Service Centres are entitled to repair these products.

⚠ WARNING

Working with laser devices

If the necessary measures for laser safety are not adopted, working with laser devices can be hazardous.

Precautions:

- ▶ Observe the User Manual of the respective laser device.
- ▶ Only use and operate the laser device as defined in the laser safety directions.

⚠ CAUTION

Rotating lasers are safe for momentary exposures but can be hazardous for deliberate staring into the beam. The beam may cause dazzle, flash-blindness and after-images, particularly under low ambient light conditions.

Precautions:

- ▶ Do not stare into the laser beam.

NOTICE

Misalignment of laser plane

Any misalignment of the laser plane will impact the grade of the work being done.

Precautions:

- ▶ Take care that the laser plane of the rotating laser is at the intended height.
- ▶ Take special care to protect the laser from impacts or bumps and make sure that the tripod is set on stable ground.

For the AC/DC power supply and the battery charger:

⚠ WARNING

Electric shock due to use under wet and severe conditions

If unit becomes wet, it may cause you to receive an electric shock.

Precautions:

- ▶ If the product becomes humid, it must not be used!
- ▶ Use the product only in dry environments, for example in buildings or vehicles.



- ▶ Protect the product against humidity.

For the AC/DC power supply and the battery charger:

⚠ WARNING

Unauthorised opening of the product

Either of the following actions may cause you to receive an electric shock:

- Touching live components
- Using the product after incorrect attempts were made to carry out repairs.

Precautions:

- ▶ Do not open the product!
- ▶ Only authorised GeoMax Service Centres are entitled to repair these products.

All hazards associated with batteries also apply to products with non-replaceable batteries.

⚠ WARNING

Dropping the product, high mechanical stress or high ambient temperature

Possible damage to the internal non-removeable battery may occur. International transportation regulations might prohibit transportation of those batteries.

- ▶ Do not ship or transport by air.
- ▶ Send the affected product to the local customer service under consideration of the local transportation regulations.

 **WARNING**

Inappropriate mechanical influences to batteries

During the transport, shipping or disposal of batteries it is possible for inappropriate mechanical influences to constitute a fire hazard.

Precautions:

- ▶ Before shipping the product or disposing it, discharge the batteries by the product until they are flat.
- ▶ When transporting or shipping batteries, the person in charge of the product must ensure that the applicable national and international rules and regulations are observed.
- ▶ Before transportation or shipping, contact your local passenger or freight transport company.

 **WARNING**

Exposure of batteries to high mechanical stress, high ambient temperatures or immersion into fluids

This can cause leakage, fire or explosion of the batteries.

Precautions:

- ▶ Protect the batteries from mechanical influences and high ambient temperatures. Do not drop or immerse batteries into fluids.

 **WARNING**

Short circuit of battery terminals

If battery terminals are short circuited e.g. by coming in contact with jewellery, keys, metallised paper or other metals, the battery can overheat and cause injury or fire, for example by storing or transporting in pockets.

Precautions:

- ▶ Make sure that the battery terminals do not come into contact with metallic/conductive objects.

 **WARNING**

Short circuit of battery terminals

Risk of fire, electric shock and damage.

Precautions:

- ▶ Do not open the battery housing.
- ▶ Keep away any metallic or wet objects from the battery terminals.

 **WARNING**

Battery pack of the signal transmitter may get hot after prolonged use

Risk of burning injuries.

Precautions:

- ▶ Avoid touching the hot battery pack.
- ▶ Allow the battery pack to cool down before removing it.

 **WARNING**

Damaged battery

If batteries are damaged or are heated strongly, they can explode and cause poisoning, burning, corrosion or environmental contamination.

Precautions:

- ▶ Protect the battery against mechanical damages.

⚠ WARNING

Damaged battery housing

There is a risk of fire. In case skin or eyes have come into direct contact with electrolytes leaking from the battery, rinse them thoroughly with clear water. Immediately contact a doctor.

Precautions:

- ▶ Stop using the battery.
- ▶ Turn off any charging in action.
- ▶ If any electrolytes should leak from a damaged battery, avoid skin contact and direct inhalation of gases.

⚠ WARNING

Improper battery handling

Risk of fire, explosion or burn.

Precautions:

- ▶ Only replace battery with supported type.
- ▶ Prevent heating the battery above 70 °C.
- ▶ Never throw battery into fire.
- ▶ Do not disassemble, crush, or modify the battery.

1.6

Laser Classification

1.6.1

General

General

The following chapters provide instructions and training information about laser safety according to international standard IEC 60825-1 (2014-05) and technical report IEC TR 60825-14 (2004-02). The information enables the person responsible for the product and the person who actually uses the equipment, to anticipate and avoid operational hazards.



According to IEC TR 60825-14 (2004-02), products classified as laser class 1, class 2 and class 3R do not require:

- laser safety officer involvement
- protective clothes and eyewear
- special warning signs in the laser working area

if used and operated as defined in this User Manual due to the low eye hazard level.



National laws and local regulations could impose more stringent instructions for the safe use of lasers than IEC 60825-1 (2014-05) and IEC TR 60825-14 (2004-02).

1.6.2

Zone40 T

General

The rotating laser built into the product produces a visible laser beam which emerges from the rotating head.

The laser product described in this section is classified as laser class 1 in accordance with:

- IEC 60825-1 (2014-05): "Safety of laser products"

These products are safe for momentary exposures but can be hazardous for deliberate staring into the beam. The beam may cause dazzle, flash-blindness and after-images, particularly under low ambient light conditions.

Description	Value
Maximum peak radiant output power	0.6 mW/3.5 mW
Pulse duration (effective)	500 ms/1.4 ms
Pulse repetition frequency	1 Hz/10 Hz
Beam divergence	0.2 mrad
Wavelength	635 nm

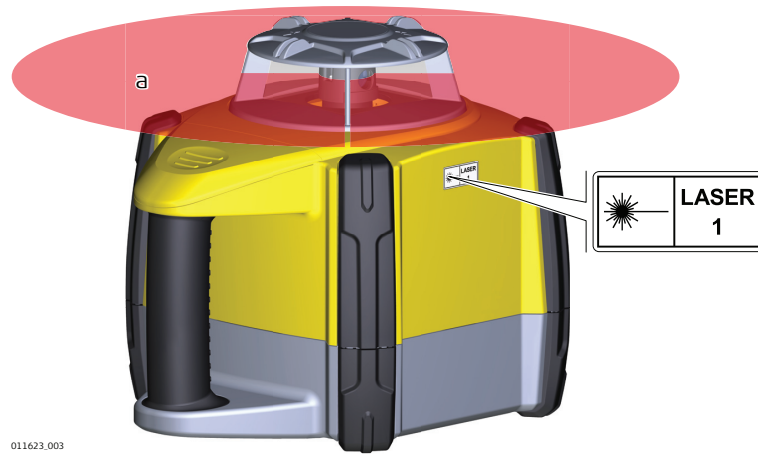

a Laser beam

1.7

Electromagnetic Compatibility (EMC)

Description

The term Electromagnetic Compatibility is taken to mean the capability of the product to function smoothly in an environment where electromagnetic radiation and electrostatic discharges are present, and without causing electromagnetic disturbances to other equipment.

CAUTION

Electromagnetic radiation

Electromagnetic radiation can cause disturbances in other equipment.

Precautions:

- ▶ Although the product meets the strict regulations and standards which are in force in this respect, GeoMax cannot completely exclude the possibility that other equipment may be disturbed.
- ▶ The product is a class A product when operated with the internal batteries. In a domestic environment this product may cause radio interference in which case the user may be required to take adequate measures.

CAUTION

Use of the product with accessories from other manufacturers. For example, field computers, personal computers or other electronic equipment, non-standard cables or external batteries

This may cause disturbances in other equipment.

Precautions:

- ▶ Use only the equipment and accessories recommended by GeoMax.
- ▶ When combined with the product, other accessories must meet the strict requirements stipulated by the guidelines and standards.
- ▶ When using computers, two-way radios or other electronic equipment, pay attention to the information about electromagnetic compatibility provided by the manufacturer.

CAUTION

Intense electromagnetic radiation. For example, near radio transmitters, transponders, two-way radios or diesel generators

Although the product meets the strict regulations and standards which are in force in this respect, GeoMax cannot completely exclude the possibility that the function of the product may be disturbed in such an electromagnetic environment.

Precautions:

- ▶ Check the plausibility of results obtained under these conditions.

 **CAUTION**

Electromagnetic radiation due to improper connection of cables

If the product is operated with connecting cables, attached at only one of their two ends, the permitted level of electromagnetic radiation may be exceeded and the correct functioning of other products may be impaired. For example, external supply cables or interface cables.

Precautions:

- ▶ While the product is in use, connecting cables, for example product to external battery or product to computer, must be connected at both ends.
-

www.PrismGeoSystems.com

2 Description of the System

2.1 System Components

General description

The Zone40 T is a laser tool for general construction and levelling applications such as:

- Setting forms.
- Levelling applications.
- Levelling.
- Controlling depths for excavations.

If set up within the self-levelling range, the Zone40 T automatically levels to create an accurate horizontal plane of laser light.

Once the Zone40 T has levelled, the head starts rotating and the Zone40 T is ready for use.

30 seconds after the Zone40 T has completed the levelling, the Height of Instrument Alert (H.I.Alert) function becomes active and protects the Zone40 T against changes in elevation caused by movement of the tripod to ensure accurate work.

Area of application

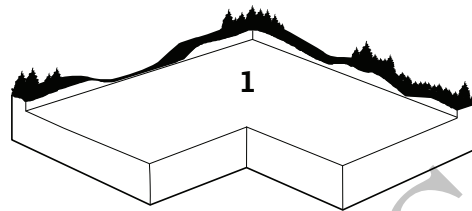

The Zone40 T is a horizontal laser only. No grade is possible. It produces an accurate plane of laser light for applications which require a level surface (1).

Available system components

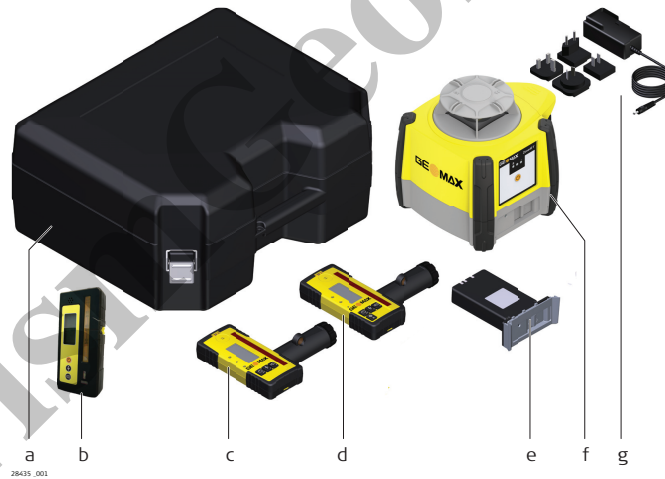

- a Container
- b ZRB90 receiver
- c ZRP105 receiver
- d ZRD105 receiver
- e Li-Ion battery
- f Zone40 T
- g Lithium-Ion charger

The delivered components depend on the package ordered.

2.2

Zone40 T Laser Components

Zone40 T laser components



28437_001

- a Carry handle
- b LED indicators
- c Power button
- d Battery compartment
- e Charge LED (for Li-Ion battery pack)

2.3

Case Components

Case components

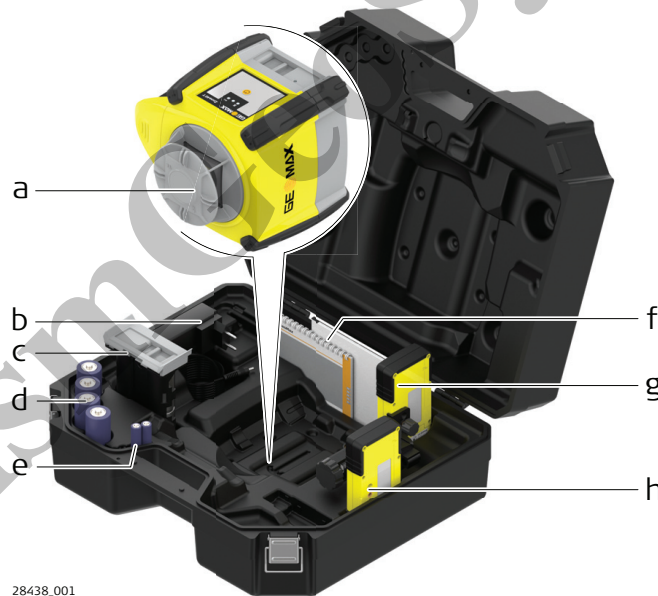

28438_001

- a Zone40 T laser
- b Charger (for Li-Ion version only)
- c Li-Ion battery pack or alkaline battery pack
- d 4x D-cell battery (for alkaline version only)
- e 2x AA-cell battery
- f User Manual CD
- g Receiver mounted on the bracket
- h Second receiver (can be purchased separately)

2.4

Location

Setup

- Keep the location clear of possible obstructions that could block or reflect the laser beam.
- Place the Zone40 T on stable ground. Ground vibration and extremely windy conditions can affect the operation of the Zone40 T.
- When working in a very dusty environment place the Zone40 T up-wind so the dirt is blown away from the laser.

Setting up on a tripod



28510_001

1. Set up the tripod.
2. Place the Zone40 T on the tripod.
3. Tighten the screw on the underside of the tripod to secure the Zone40 T on the tripod.

- Attach the Zone40 T securely to a tripod or laser trailer, or mount on a stable level surface.
- Always check the tripod or laser trailer before attaching the Zone40 T. Make sure all screws, bolts and nuts are tight.
- If a tripod has chains, they should be slightly loose to allow for thermal expansion during the day.
- Secure the tripod on windy days.

3 Operation

3.1 Control Panel

Overview

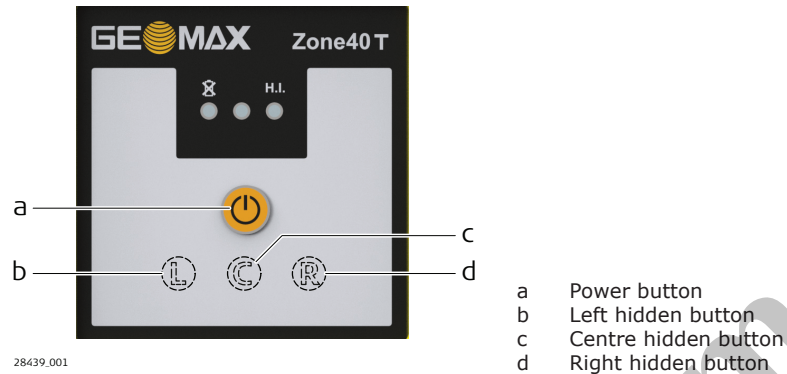

Description of the buttons

Button	Function
Power	Press to turn on or off the Zone40 T. Press and hold for five seconds (five beeps) to turn on the Zone40 T in manual mode. The Zone40 T first levels and then switches to manual mode.
Left hidden button Centre hidden button Right hidden button	With the Zone40 T turned on, press and hold the left hidden button and right hidden button. Then press the centre hidden button to enable or disable the height of instrument alert function. ☞ The Zone40 T beeps once to indicate the change.

3.2 Turning the Zone40 T On and Off

Turning on and off

Press the Power button to turn on or off the Zone40 T.

After turning on:

- If set up within the 6° self-levelling range, the Zone40 T automatically levels to create an accurate horizontal plane of laser light.
- Once levelled, the head starts rotating and Zone40 T is ready for use.
- After 30 seconds of completing the levelling, the H.I. Alert system becomes active to protect the laser against changes in elevation caused by movement or settling of the tripod.
- The self-levelling system and H.I. Alert function continues to monitor the position of the laser beam to ensure consistent and accurate work.

3.3 LED Indicators

Main functions

Description

The LED indicators have three main functions:

- To indicate the level status of the axes.
- To indicate the battery status.
- To indicate an H.I.Alert condition.

Diagram of the LED indicators



- a Low battery indicator LED
- b Level indicator LED
- c H.I.Alert indicator LED

Description of the LED

IF the	is/are	THEN
Low battery indicator LED (Li-Ion)	off	the battery is okay.
	flashing slowly	the battery has $\leq 10\%$ (4 h) power remaining.
	flashing quickly	the battery has $\leq 5\%$ (2 h) power remaining.
	red	the battery cannot power the Zone40 T. Charge the battery.
Low battery indicator LED (alkaline)	off	the battery is okay.
	flashing slowly	the battery is getting low.
	flashing rapidly	the battery must be changed.
Level indicator LED	green	the axis is level.
	flashing green	the axis is levelling.
	red	the axis is in Manual Mode.
H.I.Alert indicator LED	flashing red rapidly	movement of the laser has triggered an H.I.Alert.

3.4

Automatic Mode

Automatic Mode

In Automatic Mode the Zone40 T automatically levels if set up within the 6° self-levelling range.

3.5

Manual Mode

Manual Mode

Manual slopes can be created using the Zone40 T together with a manual slope adapter.

In Manual Mode, the self-levelling is deactivated.



After turning the Zone40 T off and on again, the Zone40 T is in Automatic Mode.

Change to Manual Mode

Press and hold the Power Button for five seconds to change to the Manual Mode.

- The Zone40 T beeps five times while holding the Power Button.
- After releasing the button, the Zone40 T levels. The levelling LED flashes green, then turns solid green for a few seconds.
- After levelling, the levelling LED turns red and the Zone40 T is in Manual Mode.

3.6

Height of Instrument Alert (H.I.Alert) function

Description of the H.I.Alert function

- The H.I.Alert function prevents incorrect work caused by movement or settling of the tripod that would cause the laser to level at a lower height.
- The H.I.Alert function becomes active and monitors the movement of the laser 30 second after the Zone40 T has levelled and the head of the laser starts rotating.
- The H.I.Alert monitors the laser. If disturbed, both the X-axis LED and Y-axis LED flash and the Zone40 T beeps rapidly.
- To stop the alert turn Zone40 T off and on again. Check the height of the laser before beginning to work again.



The H.I.Alert function turns on automatically every time the Zone40 T is turned on.

Disable/enable the H.I.Alert function

The H.I.Alert function can be disabled or enabled by pressing the following button combination:

- With the Zone40 T turned on, press and hold the left hidden button and the right hidden button.
- Press the centre hidden button.



The Zone40 T beeps once to indicate the change.

4

Receiver

Description

The Zone40 T is sold with the ZRB90, ZRP105 or ZRD105 Receiver.

4.1

ZRB90, Basic Receiver

Instrument components part 1 of 2

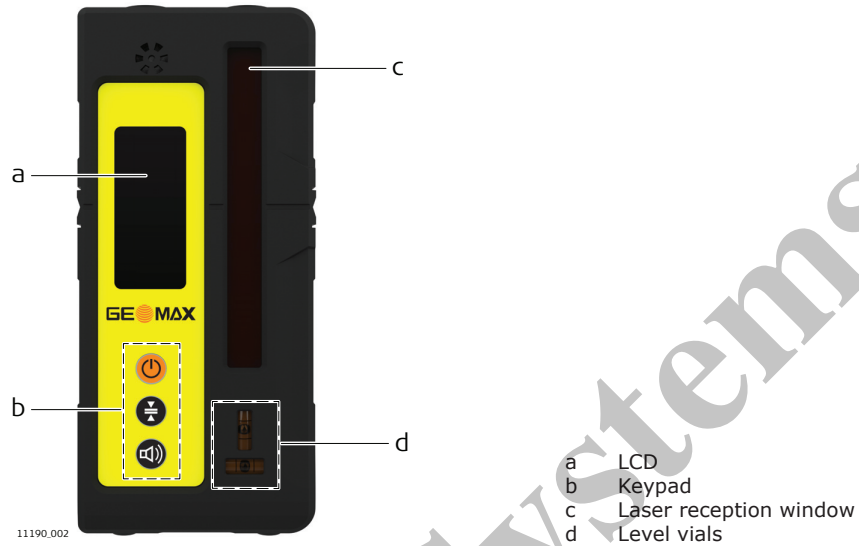

Component	Description
LCD	Front and rear LCD arrow indicate the detectors position.
Keypad	Power, accuracy and volume functions.
Laser reception window	Detects the laser beam. The reception window must be directed towards the laser.
Level vials	Aids to keep the rod plumb when taking readings.

Instrument components part 2 of 2

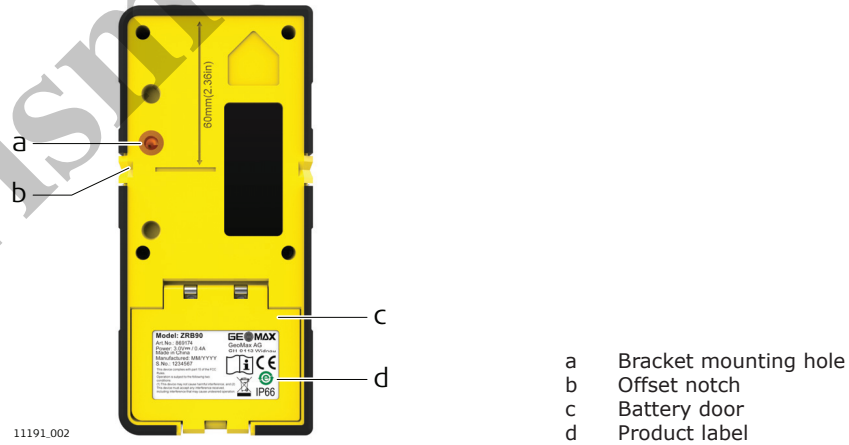

Component	Description
Bracket mounting hole	Location to attach the receiver bracket for normal operation.
Offset notch	Use to transfer reference marks. The notch is 45 mm (1.75") below to top of the detector.

Component	Description
Battery door	Access to the battery compartment.
Product label	The serial number is located inside the battery compartment.

Description of the buttons

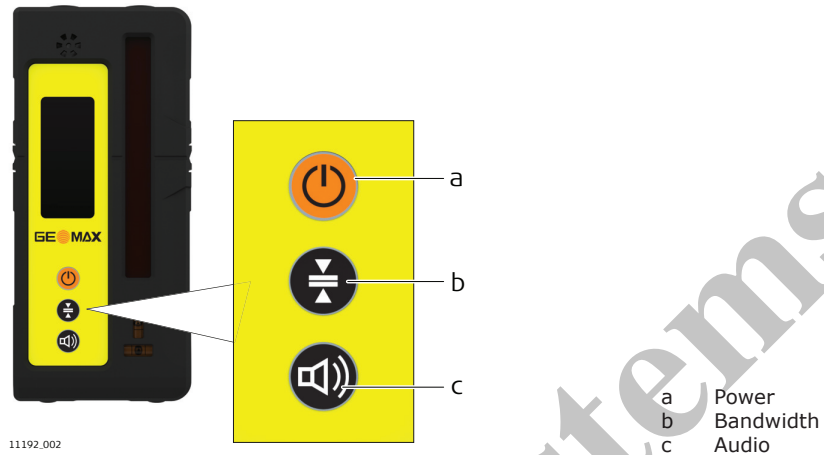

Button	Function
Power	Press once to turn on the receiver.
Bandwidth	Press to change detection bandwidth.
Audio	Press to change the audio output.

4.2

Instrument components part 1 of 2

ZRP105, Pro Receiver



Component	Description
Level vial	Aids to keep the rod plumb when taking readings.
Audio Speaker	Indicates the detector's position: <ul style="list-style-type: none"> High - Fast beeping On-grade - Solid tone Low - Slow beeping
LCD window	Front and rear LCD arrow indicate the detector's position.
LEDs	Display the relative position of the laser beam. Three channel indication: <ul style="list-style-type: none"> High - Red On-grade - Green Low - Blue
Laser Reception window	Detects the laser beam. The reception windows must be directed towards the laser.

Component	Description
On-grade	Indicates the on-grade position of the laser.
Keypad	Power, accuracy and volume functions.

Instrument components part 2 of 2



011194_001

- a Bracket mounting hole
- b Offset notch
- c Product label
- d Battery door

Component	Description
Bracket mounting hole	Location to attach the receiver bracket for normal operation.
Offset notch	Use to transfer reference marks. The notch is 85 mm (3.35") below to top of the detector.
Product label	The serial number is located inside the battery compartment.
Battery door	Access to the battery compartment.

Description of the buttons



011195_002

- a Power
- b Audio
- c Bandwidth

Button	Function
Power	Press once to turn on the receiver.
Audio	Press to change the audio output.
Bandwidth	Press to change detection bandwidth.

Menu access and navigation

To access the menu of the ZRP105 Receiver, press the Bandwidth button and Audio button simultaneously.

- Use the Bandwidth button and Audio button to change parameters.
- Use the Power button to scroll through the menu.

Menu

 MENU MODE - The blue LED will blink slowly indicating menu mode.

Menu	Function	Indication
UNT	Changes the unit of measure for the digital readout.	 Units - mm/cm/in/ft Active unit flashes.

Menu	Function	Indication
LED	Changes the brightness of the LED indicators.	Red and green LEDs - High/Low/Off
Red and Green LEDs change brightness to indicate this parameter.		
BAT	Turns on or off the Laser low battery indication on the receiver.	Green LED is on: Laser low battery icon function is active. Red LED is on: Laser low battery icon function is not active.
The laser icon flashes to indicate this parameter.		
MEM	Turns on or off the position memory function.	Green LED is on: function is on. Red LED is on: function is off.
The down arrow bars are filling to indicate this parameter.		

4.3

ZRD105, Digital Receiver

Description

The ZRD105 Digital Receiver provides you with basic position information by using an arrow display plus digital readout.

Instrument components

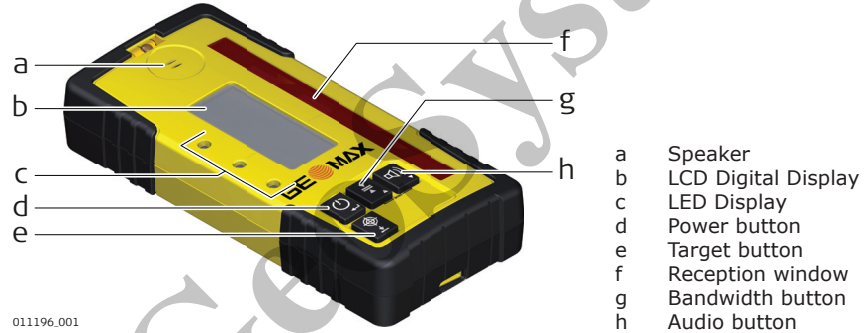

Description of the buttons

Button	Function
Power	Press once to turn on the receiver.
	Press 1.5 seconds to turn off the receiver.
Target	Press to capture the digital reading.
Bandwidth	Press to change detection bandwidths.
Audio	Press to change the audio output.

5 Applications

5.1 Setting Forms

Setting Forms

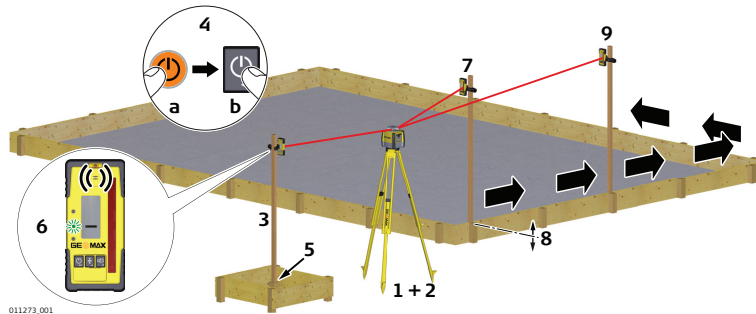

Step	Description
1.	Set up the Zone40 T on a tripod.
2.	Set up the tripod on a stable surface outside the working area.
3.	Attach the receiver to a rod.
4.	Turn on the Zone40 T and the receiver.
5.	Set the base of the rod on a known point for the finished height of forms.
6.	Adjust the height of the receiver on the rod until the on-grade (centre-line) position is indicated on the receiver by: <ul style="list-style-type: none"> • the centre bar • the green flashing LED • a solid audio tone • the digital display
7.	Set the rod with the attached receiver on top of the form.
8.	Adjust the height of the form until the on-grade position is again indicated.
9.	Continue to additional positions until the forms are levelled to the rotating plane of the Zone40 T.

6

Batteries

Description

The Zone40 T can be purchased with alkaline batteries or a rechargeable Li-Ion battery pack.

The following information is appropriate only to the model you have purchased.

6.1

Operating Principles

First-time use/ charging batteries

- The battery must be charged before using it the first time, because it is delivered with an energy content as low as possible or might be in sleep mode.
- The permissible temperature range for charging is from 0 °C to +40 °C/+32 °F to +104 °F. For optimal charging, we recommend charging the batteries at a low ambient temperature of +10 °C to +20 °C/+50 °F to +68 °F if possible
- It is normal for the battery to become warm during charging. Using the chargers recommended by GeoMax, it is not possible to charge the battery once the temperature is too high
- For new batteries or batteries that have been stored for a long time (> three months), it is effectual to make a discharge/charge cycle
- For Li-Ion batteries, a single discharge/charge cycle is sufficient. We recommend carrying out the process when the battery capacity indicated on the charger or on a GeoMax product deviates significantly from the actual battery capacity available.

Operation/discharging

- The batteries can be operated from -20 °C to +55 °C/-4 °F to +131 °F.
- Low operating temperatures reduce the capacity that can be drawn; high operating temperatures reduce the service life of the battery.

6.2

Battery for Zone40 T

Charging the Li-Ion battery pack

The rechargeable Li-Ion battery pack on the Zone40 T can be charged without removing the battery pack from the laser.



1. Slide the locking mechanism on the battery compartment to the centre and expose the charge jack.
2. Plug the AC connector into the appropriate AC power source.
3. Connect the charger plug into the charge jack on the Zone40 T battery pack.
4. The small LED next to the charge jack flashes indicating that the Zone40 T is charging.
☞ The LED is on solid when the battery pack is fully charged.
5. Disconnect the charger plug from the charge jack.
6. Slide the locking mechanism to the left (closed) position, to prevent foreign object contamination.



The battery pack reaches a full charge in approximately five hours if empty. A one-hour charge should allow the Zone40 T to run for a full eight hours.

Changing the Li-Ion battery pack

With the Li-Ion battery pack, the battery indicator on the Zone40 T indicates when the battery pack is low and must be charged. The charge indicator LED on the Li-Ion battery pack indicates when the battery pack is being charged (flashing slowly) or fully charged (on, not flashing).



28449_001



The battery pack is inserted in the front of the laser.



The battery pack can be recharged without being removed from the laser. Refer to [Charging the Li-Ion battery pack](#) for further information.

1. Slide the locking mechanism on the battery pack to the right.
2. To remove the battery pack:
Remove the battery pack from the Zone40 T.

To insert the battery pack:
Insert the battery pack into the Zone40 T.
3. Slide the locking mechanism to the left until it locks into position.

Changing the alkaline batteries

With the alkaline batteries, the battery indicator on the Zone40 T LED flash when the batteries are low and must be replaced. If no battery icon is shown, the batteries are okay.



28450_001



The batteries are inserted in the front of the laser.

1. Slide the locking mechanism on the battery compartment to the right.
2. To remove the batteries:
Open the battery compartment.
Remove the batteries from the battery compartment.
3. To insert the batteries:
Insert the batteries into the battery compartment, ensuring that the contacts are facing in the right direction.
 The correct polarity is displayed on the battery compartment.
Close the battery compartment.
4. Slide the locking mechanism to the left until it locks into position.





8

Troubleshooting

8.1

Zone40 T

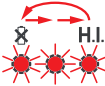
Alerts

Alert	Symptom	Possible causes and solutions
	Low battery LED flashes red, or is on but not flashing.	The batteries are low. Replace the alkaline batteries or recharge the Li-Ion battery pack. Refer to Changing the Li-Ion battery pack .
	H.I.Alert The LED flashes quickly with an audio beep.	The Zone40 T has been bumped or tripod was moved. Turn off Zone40 T to stop alert check the height of the laser before beginning to work again. Allow Zone40 T to relevel and check the height of the laser. After two minutes in the alert condition, the unit will shut off automatically.
	Servo limit alert All LED flash sequentially.	The Zone40 T is tipped too far to reach a level position. Relevel the Zone40 T within the six degree self-leveling range. This alert is also displayed any time the unit is tipped more than 45° from level. After two minutes in the alert condition, the unit will shut off automatically.
	Temperature alert All LED are on but not flashing.	The Zone40 T is in an environment where it cannot operate without causing damage to the laser diode. This could be a result of heat from direct sunlight. Shade the Zone40 T from the sun. After two minutes in the alert condition, the unit will shut off automatically.

Troubleshooting

Problem	Possible Causes	Suggested Solutions
Zone40 T does not turn on.	The batteries are low or dead.	Check the batteries and change or charge the batteries if necessary. If the problem continues, return the Zone40 T to an authorised service centre for service.
The distance of the laser is reduced.	Dirt is reducing the laser output.	Clean the windows of the Zone40 T and the receiver. If the problem continues, return the Zone40 T to an authorised service centre for service.
The laser receiver is not working properly.	The Zone40 T is not rotating. It may be levelling or in H.I.Alert.	Check for proper operation of the Zone40 T.  Refer to the receiver manual for more information.
	The receiver is out of usable range.	Move closer to the Zone40 T.
	The batteries of the receiver are low.	Change the receiver batteries.

Problem	Possible Causes	Suggested Solutions
H.I.Alert function is not working.	The H.I.Alert function is disabled.	The H.I.Alert function is enabled or disabled by pressing the following button combination: With Zone40 T turned on and rotating, press and hold the left hidden button and the right hidden button. Then press the centre hidden button to enable or disable the H.I.Alert function. The Zone40 T beeps once to indicate the change.

www.PrismGeoSystems.com

9 Care and Transport

9.1 Transport

On-site transport

When transporting the equipment in the field, always make sure that you

- either carry the product in its original container,
- or carry the tripod with its legs splayed across your shoulder, keeping the attached product upright.

Transport in a road vehicle

Never carry the product loose in a road vehicle, as it can be affected by shock and vibration. Always carry the product in its container and secure it.

For products for which no container is available use the original packaging or its equivalent.

Shipping

When transporting the product by rail, air or sea, always use the complete original GeoMax packaging, container and cardboard box, or its equivalent, to protect against shock and vibration.

Shipping, transport of batteries

When transporting or shipping batteries, the person responsible for the product must ensure that the applicable national and international rules and regulations are observed. Before transportation or shipping, contact your local passenger or freight transport company.

Field adjustment

Exposing the product to high mechanical forces, for example through frequent transport or rough handling, or storing the product for a long time may cause deviations and a decrease in the measurement accuracy. Periodically carry out test measurements and perform the field adjustments indicated in the User Manual before using the product.

9.2

Storage

Product

Respect the temperature limits when storing the equipment, particularly in summer if the equipment is inside a vehicle. Refer to [10 Technical Data](#) for information about temperature limits.

Li-Ion and alkaline batteries

For Li-Ion and alkaline batteries

- Refer to [10 Technical Data](#) for information about storage temperature range
- Remove batteries from the product and the charger before storing
- After storage recharge batteries before using
- Protect batteries from damp and wetness. Wet or damp batteries must be dried before storing or use

For Li-Ion batteries

- A storage temperature range of 0 °C to +30 °C / +32 °F to +86 °F in a dry environment is recommended to minimize self-discharging of the battery
- At the recommended storage temperature range, batteries containing a 40% to 50% charge can be stored for up to one year. After this storage period the batteries must be recharged

9.3

Cleaning and Drying

Product and accessories

- Blow dust off lenses and prisms.
- Never touch the glass with your fingers.
- Use only a clean, soft, lint-free cloth for cleaning. If necessary, moisten the cloth with water or pure alcohol. Do not use other liquids; these may attack the polymer components.

Damp products

Dry the product, the transport container, the foam inserts and the accessories at a temperature not greater than 40°C /104°F and clean them. Remove the battery cover and dry the battery

compartment. Do not repack until everything is completely dry. Always close the transport container when using in the field.

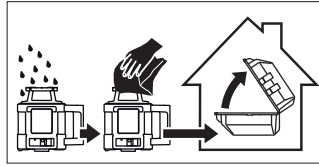

Cables and plugs

Keep plugs clean and dry. Blow away any dirt lodged in the plugs of the connecting cables.

www.PrismGeoSystems.com

10

Technical Data

10.1

Conformity to National Regulations

Labelling Zone40 T



GEOMAX
GeoMax AG
CH-9443 Widnau

Complies with 21 CFR 1040.10 and 1040.11 except for conformance with IEC 60825-1 Ed. 3, as described in Laser Notice No. 56, dated May 8, 2019.

This device complies with part 15 of the FCC Rules. Operation is subject to the following two conditions: (1) This device may not cause harmful interference, and (2) This device must accept any interference received, including interference that may cause undesired operation.

Model: Zone40 T
Power: 8.4V \approx / 0.5A/ Art.No.: 987619
Made in China/ Manufactured: MM/YYYY

Class 1 Laser - IEC 60825-1:2014

Serial Number: YWY4T40000

CE, RoHS, REACH, IP66

28454.001

Labelling receiver ZRB90



Model: ZRB90
Art.No.: 869174
Power: 3.0V \approx / 0.4A
Made in China
Manufactured: MM/YYYY
S.No.: 1234567

GEOMAX
GeoMax AG
CH-9443 Widnau

This device complies with part 15 of the FCC Rules. Operation is subject to the following two conditions: (1) This device may not cause harmful interference, and (2) This device must accept any interference received, including interference that may cause undesired operation.

IP66

11178.003

Labelling receiver

ZRP105:



Model: ZRP105
Art.No.: 835247
Power: 3V \approx / 60mA
Made in China
Manufactured: MM/YYYY
S.No.: 1234567

GEOMAX
GeoMax AG
CH-9443 Widnau

This device complies with part 15 of the FCC Rules. Operation is subject to the following two conditions: (1) This device may not cause harmful interference, and (2) This device must accept any interference received, including interference that may cause undesired operation.

011177.002

Labelling receiver

ZRD105:



Type: ZRD105
 Art.No.: 835248
 Power: 3V \pm / 60mA
 Made in China
 Manufactured: MM/YYYY
 S.No.: 1234567

GEOMAX
 GeoMax AG
 CH-9443 Widnau

This device complies with part 15 of the FCC Rules. Operation is subject to the following two conditions:
 (1) This device may not cause harmful interference, and
 (2) This device must accept any interference received, including interference that may cause undesired operation.

11243_003

EU



Hereby, GeoMax AG declares that the product/s is/are in compliance with the essential requirements and other relevant provisions of the applicable European Directives.
 The full text of the EU declaration of conformity is available at the following Internet address:
<https://geomax-positioning.com/partner-area>.

USA

FCC Part 15 B

This equipment has been tested and found to comply with the limits for a Class B digital device, pursuant to part 15 of the FCC Rules.

These limits are designed to provide reasonable protection against harmful interference in a residential installation.

This equipment generates, uses, and can radiate radio frequency energy and, if not installed and used in accordance with the instructions, it may cause harmful interference to radio communications.

However, there is no guarantee that interference does not occur in a particular installation. If this equipment does cause harmful interference to radio or television reception, which can be determined by turning the equipment off and on, the user is encouraged to try to correct the interference by one or more of the following measures:

- Reorient or relocate the receiving antenna.
- Increase the separation between the equipment and the receiver.
- Connect the equipment into an outlet on a circuit different from that to which the receiver is connected.
- Consult the dealer or an experienced radio/TV technician for help.

Changes or modifications not expressly approved by GeoMax for compliance could void the user's authority to operate the equipment.

Canada

CAN ICES-003 B/NMB-003 B

Others

The conformity for countries with other national regulations has to be approved prior to use and operation.

10.2

Dangerous Goods Regulations

Dangerous Goods Regulations

The products of GeoMax are powered by Lithium batteries.

Lithium batteries can be dangerous under certain conditions and can pose a safety hazard. In certain conditions, Lithium batteries can overheat and ignite.



When carrying or shipping your GeoMax product with Lithium batteries onboard a commercial aircraft, you must do so in accordance with the **IATA Dangerous Goods Regulations**.



GeoMax has developed **Guidelines** on “How to carry GeoMax products” and “How to ship GeoMax products” with Lithium batteries. Before any transportation of a GeoMax product, we ask you to consult these guidelines on our web page (<http://www.geomax-positioning.com/dgr>) to ensure that you are in accordance with the IATA Dangerous Goods Regulations and that the GeoMax products can be transported correctly.



Damaged or defective batteries are prohibited from being carried or transported onboard any aircraft. Therefore, ensure that the condition of any battery is safe for transportation.

10.3

General Technical Data of the Product

Operating range

Operating range (diameter):

Type	Value
Zone40 T	1100 m/3600 ft

Self-levelling accuracy

Type	Value
Self-levelling accuracy ¹⁾	±1.5 mm at 30 m (±1/16" at 100 ft)

Self-levelling range

Type	Value
Self-levelling range	±6°

Rotational speed

Type	Value
Rotational speed	10 rps

Laser Dimensions



Weight

Zone40 T weight with battery:

3.16 kg/7.0 lbs.

Internal battery

Type	Operating times* at 20°C
Lithium-Ion (Li-Ion Pack)	40 h
Alkaline (four D-cells)	40 h

*Operating times are dependent upon environmental conditions.



Charging the Li-Ion battery pack takes a maximum of five hours.

¹⁾ Self-levelling accuracy is defined at 25 °C (77 °F).



Use only high quality alkaline batteries to achieve operating time.

Environmental specifications

Temperature

Operating temperature	Storage temperature
-20°C to +50°C (-4°F to +122°F)	-40°C to +70°C (-40°F to +158°F)

Protection against water, dust and sand

Protection
IP67 (IEC 60529) Dust tight Waterproof to 1 m temporary immersion.

10.3.1

Charger and Batteries

Lithium-Ion charger



0024774.001

Type	Value
Input voltage	100 V AC-240 V AC, 50 Hz-60 Hz
Output voltage	12 V DC
Output current	3.0 A
Polarity	Shaft: negative, Tip: positive

Lithium-Ion battery pack

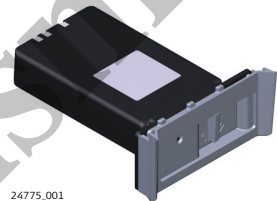

24775.001

Type	Value
Input voltage	12 V DC
Input current	2.5 A
Charge time	5 hours (maximum) at 20 °C

Weight

Lithium-Ion battery pack: 366 g / 13 oz

www.PrismGeoSystems.com

996399-1.0.0en

Original text (996399-1.0.0en)

© 2023 GeoMax AG is part of Hexagon AB.
All rights reserved.

GeoMax AG

Espenstrasse 135

9443 Widnau

Switzerland

geomax-positioning.com

